



PERFORMANCE IMPROVEMENTS OF SEPARATELY EXCITED DC MOTOR USING FUZZY LOGIC CONTROL

R. Nagarajan¹, M. Gokulkannan², T. Dinesh³, S. Murugesan⁴, M. Naveenprasanth⁵

¹ Professor, Dept. of Electrical and Electronics Engineering, Gnanamani College of Technology, Namakkal, India

^{2,3,4,5} U.G. Students, Dept. of Electrical and Electronics Engineering, Gnanamani College of Technology, Namakkal, India

Abstract:

This paper demonstrates the importance of a fuzzy logic controller over conventional method. The performance of the separately excited DC motor is analyzed by using fuzzy logic controller (FLC) in MATLAB/SIMULINK environment. The FLC speed controller is designed based on the expert knowledge of the fuzzy rules system. The proposed DC motor speed control fuzzy rules are designed for fuzzy logic controller. The output response of the system is obtained by using fuzzy logic controller. The designed fuzzy controller for speed control performance is investigated. Significantly reducing the overshoot and shortening the settling time of the speed response of the motor. They validate different control of approaches, the simulation results show improvement in motor efficiency and speed performance.

Keywords: Fuzzy Logic Controller; PID Controller; Fuzzy Inference System; Membership Function.

Cite This Article: R. Nagarajan, M. Gokulkannan, T. Dinesh, S. Murugesan, and M. Naveenprasanth. (2019). "PERFORMANCE IMPROVEMENTS OF SEPARATELY EXCITED DC MOTOR USING FUZZY LOGIC CONTROL." *International Journal of Engineering Technologies and Management Research*, 6(2), 47-58. DOI: 10.5281/zenodo.2585498.

1. Introduction

An accurate control is critical to every process that leads to various types of controllers, which are being widely used in process industries. The tuning methods for these controllers are very important for process industries. The aim of this paper is to design a fuzzy logic controller for speed control of a DC motor. Because of their high reliabilities, flexibilities and low costs [1]. The DC motors are widely used in industrial applications, robot manipulators and home appliances where speed and position control of motor are required [2]. All control systems suffer from problems related to undesirable overshoot, longer settling times and vibrations and stability while going from one state to another state. Real world systems are nonlinear, accurate modeling is difficult, costly and even impossible in most cases conventional PID controllers generally do not work well for non-linear systems. Therefore, more advanced control techniques need to be used which will minimize the noise effects. To overcome these difficulties, there are three basic approaches to intelligent control: knowledge based expert systems, fuzzy logic, and neural networks. All three approaches are interesting and very promising areas of research and

development. In this paper, we present only the fuzzy logic approach. The fuzzy logic, unlike conventional logic system, is able to model inaccurate or imprecise models. The fuzzy logic approach offers a simpler, quicker and more reliable solution that is clear advantages over conventional techniques [3], [4].

The Fuzzy Logic has been successfully applied to a large number of control applications. The most commonly used controller is the PID controller, which requires a mathematical model of the system. A fuzzy logic controller provides an alternative to the PID controller. The control action in fuzzy logic controllers can be expressed with simple “if-then” rules. Fuzzy controllers are more sufficient than classical controllers because they can cover a much wider range of operating conditions than classical controllers and can operate with noise and disturbances of a different nature [5].

2. Modeling of Separately Excited Dc Motor

The term speed control stand for intentional speed variation carried out manually or automatically. The DC motors are most suitable for wide range speed control and there are for many adjustable speed drives [6], [7]. The Fig.1 shows block diagram of separately excited DC motor model

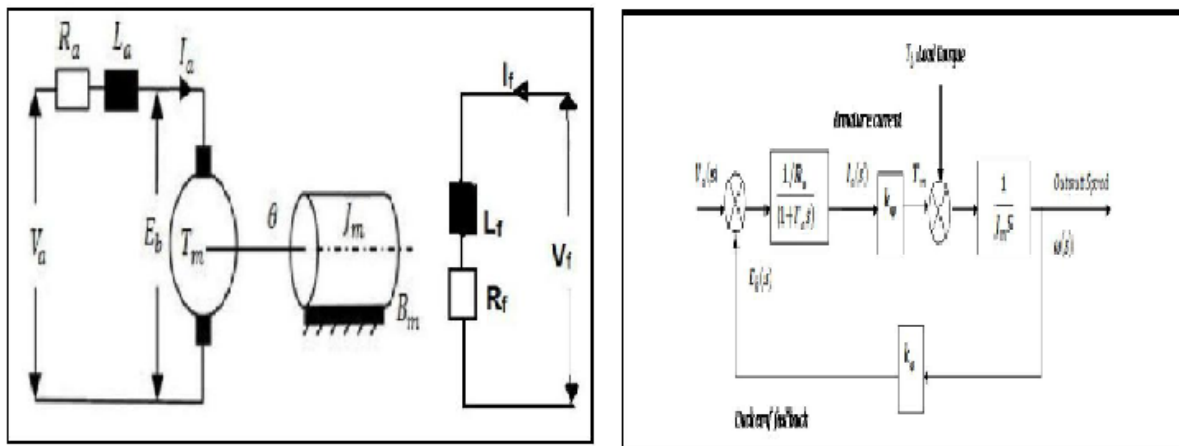

Figure 1: Block Diagram of Separately Excited DC Motor Model

The armature voltage equation is given by:

$$V_a = E_b + I_a R_a + L_a \frac{d\omega}{dt} \text{ --- (1)}$$

Now the torque balance equation will be given by:

$$T_m = J_m \frac{d\omega}{dt} + B_m \omega + T_L \text{ --- (2)}$$

Friction in rotor of motor is very small (can be neglected), so $B_m = 0$ Therefore, new torque balance equation will be given by

$$T_m = J_m \frac{d\omega}{dt} + T_L \text{ --- (2a)}$$

Taking the field flux as Φ and back emf Constant as K , the equation for back emf of motor will be:

$$E_b = K\phi \text{ --- (3)}$$

Also

$$T_m = K\phi I_a \text{ --- (4)}$$

Taking Laplace transform of the motor's armature voltage equation we get

$$I_a(s) = \frac{(V_a - E_b)}{(R_a + I_a s)} \text{ --- (5)}$$

Now, taking equation (4) into consideration, we have:

$$I_a = \frac{(V_a - K\phi\omega)}{R_a(1 + \frac{L_a s}{R_a})} \text{ --- (6)}$$

$$\omega_s = \frac{(T_m - T_L)}{J_s} = \frac{(K\phi I_a - T_L)}{J_m s} \text{ --- (7)}$$

Armature Time Constant

$$T_a = \frac{L_a}{R_a} \text{ --- (8)}$$

After simplifying the above motor model, the overall transfer function will be

$$\frac{\theta(s)}{V_a(s)} = \frac{K\phi}{L_a L_m s^2 + R_a J_m s + K^2 \phi^2} \text{ --- (9)}$$

For the DC motor with parameters the overall transfer function of the system is given as:

$$\frac{\theta(s)}{V_a(s)} = \frac{0.5}{0.002s^2 + 0.05s + 0.625} \text{ --- (10)}$$

3. Fuzzy Logic Controller

The Fuzzy logic has rapidly become one of the most successful of today's technologies for developing sophisticated control systems. The fuzzy logic control technology has been widely and successfully utilized in industrial applications. Fuzzy Logic is a multi-valued logic, that allows intermediate values to be defined between conventional evaluations like true/false, yes/no,

high/low and emerged as a tool to deal with uncertain, imprecise, or qualitative decision making problems. The fuzzy logic is a way to make machines more intelligent to reason in a fuzzy manner like humans [8], [9]. Fig. 2 shows the fuzzy logic controller model.

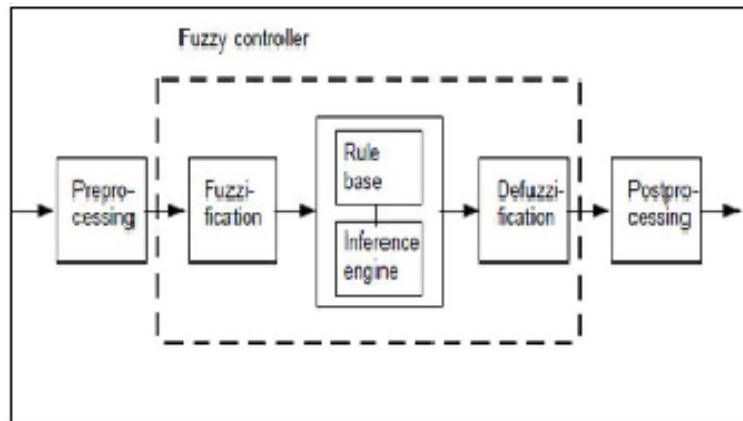

Figure 2: Fuzzy Logic Model

A fuzzy logic model is a logical-mathematical procedure based on an “IF-THEN” rule system that mimics the human way of thinking in computational form. Generally, a fuzzy rule system has four modules such as,

- Fuzzification
- Fuzzy Inference
- Rule Base
- Defuzzification

Fuzzification

The Fuzzy number is called Fuzzification. In others words, means the assigning of linguistic value, defined by relative small number of membership functions to variable.

Fuzzy Inference

Under inference, the truth value for the premise of each rule is computed, and applied to the conclusion part of each rule. This results in one fuzzy subset to be assigned to each output variable for each rule. Mostly MIN or PRODUCT is used as inference rules. In MIN inference, the output membership function is clipped off at a height corresponding to the rule premise's computed degree of truth (fuzzy logic AND). In PRODUCT inference, the output membership function is scaled by the rule premise's computed degree of truth.

Rule Base

For the rule bases a classic interpretation of Mandani was used. Under rule base, rules are constructed for outputs. The rules are in “If Then” format and formally the If side is called the conditions and the Then side is called the conclusion. A rule base controller is easy to understand and easy to maintain for a non-specialist end user and an equivalent controller could be implemented using conventional techniques

Defuzzification

The Defuzzification is a process in which crisp output is obtained by the fuzzy output. In other words, process of converting fuzzy output to crisp number. There is more Defuzzification methods in which two of the more common techniques are the CENTROID and MAXIMUM methods. In the CENTROID method, the crisp value of the output variable is computed by finding the variable value of the centre of gravity of the membership function for the fuzzy value. In the maximum method, one of the variable values at which the fuzzy subset has its maximum truth value is chosen as crisp value for the output variable

Designing Procedure

This paper presents a methodology for rule base fuzzy logic controller applied to a system. Before running the simulation in MATLAB/Simulink, the fuzzy logic controller is to be designed. This is done using the FIS editor [10]-[13]. The FIS file is created using the fuzzy logic toolbox. The design of a fuzzy logic controller requires the choice of membership functions. After the appropriate membership functions are chosen, a rule base is created. The set of linguistic rules is the essential part of a fuzzy controller. The various linguistic variables to design rule base for output of the fuzzy logic controller are shown in Fig.3. The response of the fuzzy logic controller is obtained using in MATLAB/Simulink. A two input which is speed error (e) and change in error (ec) and one-output change in control, fuzzy controller is created and the membership functions and fuzzy rules are determined. The membership functions (MF) for inputs are shown in Fig. 3(a), 3(b) and the MF for output is shown in Fig. 3(c).

Membership Functions for Inputs and Output Variables

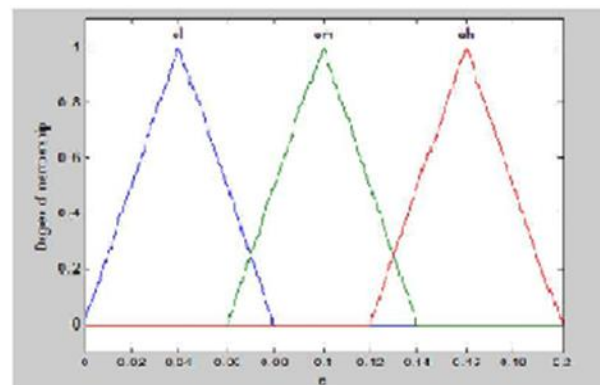
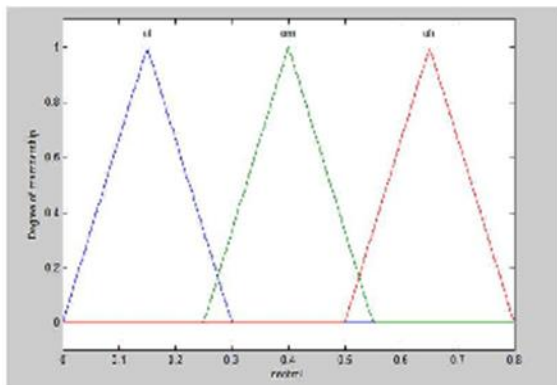

Figure 3(a): Fuzzy Input Variables “Error” Figure 3(b): Fuzzy Input Variables “Change Error”

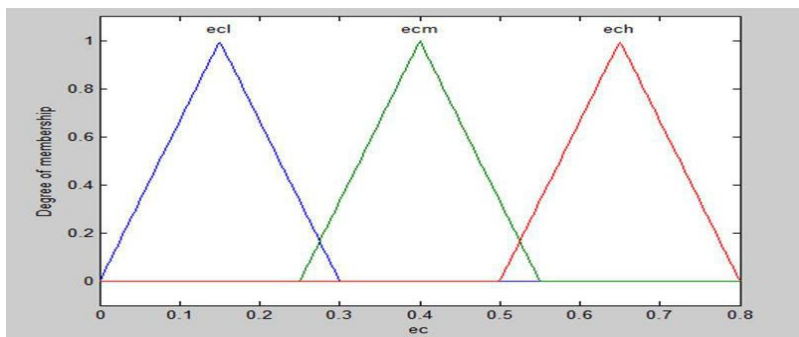

Figure 3(c): Fuzzy Output Variable “Control”

Here max-min type decomposition is used and the final output for system is calculated by using center of area gravity method. i is an index of every membership function of fuzzy set, m is the number of rules and is the inference result

Construction of Rules and Rule Viewer

In Figure 4(a) fuzzy if-then rules are shown and in Fig. 4(b) analysis of the two inputs (error and change in error) and output are shown. There are total 9 rules output variable. In Fuzzy membership function there are two input variable and each input variable have seven linguistic values.

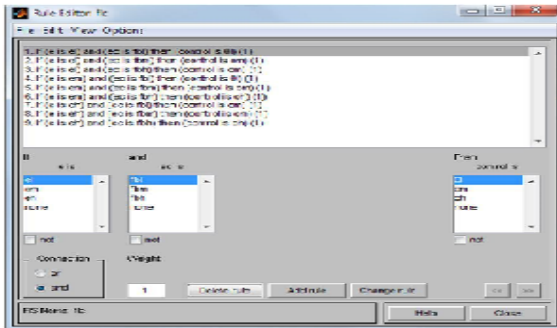

Figure 4(a) Fuzzy If-Then Rule

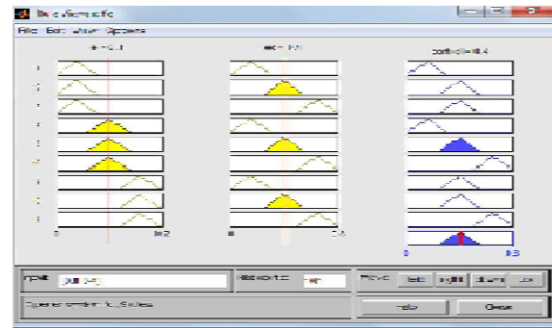

Figure 4(b): Analysis of Both the Inputs and Outputs

4. MATLAB Implementation

The results of the system with using different type of controllers are shown here. The responses of the system with several controllers such as PID, Fuzzy Logic Controller are being applied. In this section transfer of the separately excited DC motor is used as a system and find out the response of the system applying the step function as an input [14]-[18].

PID Controller

Fig. 5 shows the PID control system designed in MATLAB/Simulink where controller parameters are adjusted using (Z-N) method. The simulation output of the PID Controller for 2nd order system is represented in Fig 6.

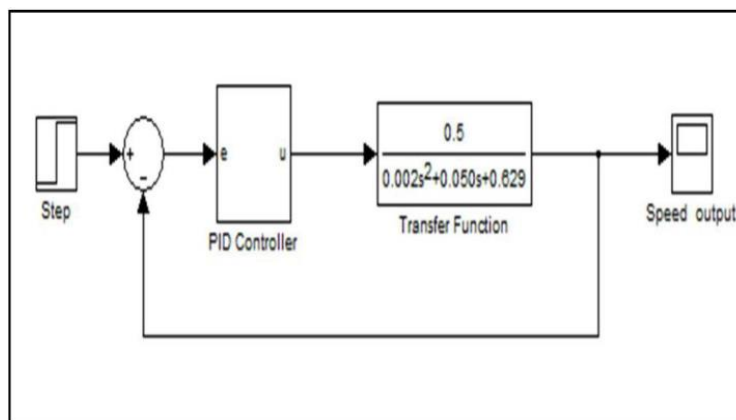

Figure 5: MATLAB/Simulink Model of PID Controller

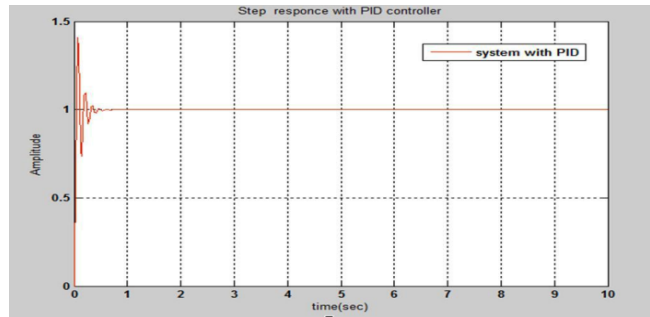

Figure 6: Step Response of the System with PID Controller

As can be seen from the Fig.6, the PID controlled response of the system has considerably high overshoot and larger settling time values. Hence, an attempt is made to further improve the response of the system using fuzzy logic controller [19]-[21].

Fuzzy Logic Controller

A fuzzy logic model is a logical-mathematical procedure based on an “IF-THEN” rule system that mimics the human way of thinking in computational form. Generally, a fuzzy rule system has four modules. There are specific components characteristic of a fuzzy controller to support a design procedure between the pre-processing block and post processing block [22]-[24]. Fig. 7 shows the MATLAB/Simulink model of system using fuzzy logic controller.

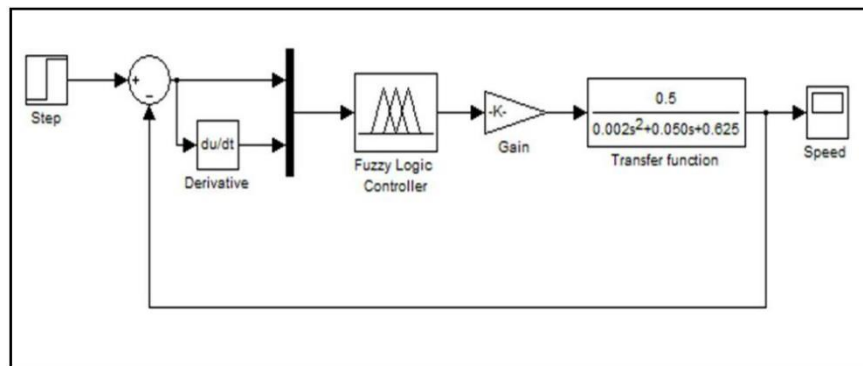

Figure 7: MATLAB/Simulink Model of Fuzzy Logic Controller

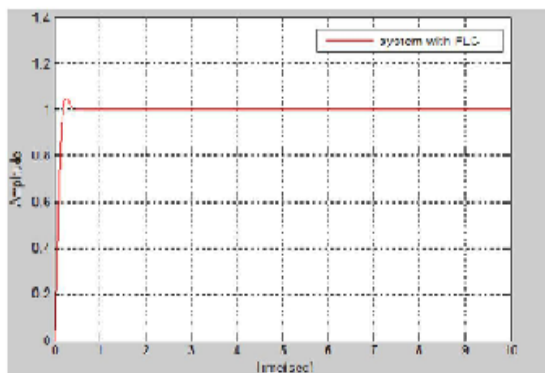

Figure 8: Step response Using FLC

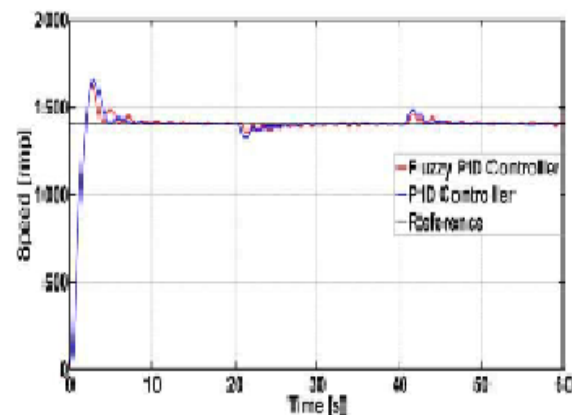

Figure 9: Step responses Using PID and FLC

The simulation output of the Fuzzy Logic Controller for System is represented in Fig. 8. From above figure, it can be easily seen that the overshoot has been considerably reduced with fuzzy logic controller as compared to the PID using classic ZN method. Comparative step response for PID regulated system and FLC controlled system is shown in Fig. 9. The Fig.9 shows that the response of the system has greatly improved on application of fuzzy logic controller. The overshoot of the system using FLC has been reduced, settling time; peak time of the system also shows appreciable reduction as analyzed in Table I.

Table 1: Comparison between PID and FLC Controllers

SL. No.	Parameters	PID	FLC
1	Rise time (sec)	0.0286	0.1240
2	Peak time (sec)	1.0763	0.2662
3	Settling time(sec)	1.3950	0.3405
4	% Overshoot	39.519	4.1997

The triangular membership functions for input variable speed error and control output i.e. change in PWM input are shown in Fig. 10. The general considerations in the design of the controller are:
 1. If both error is zero, then maintain the present control setting i.e. output=0.
 2. If the error is not zero but is approaching this value at a satisfactory rate, then maintain the present control setting.
 3. If the error is growing then change the control signal output depending on the magnitude and sign of error to force the error towards zero [25]-[28].

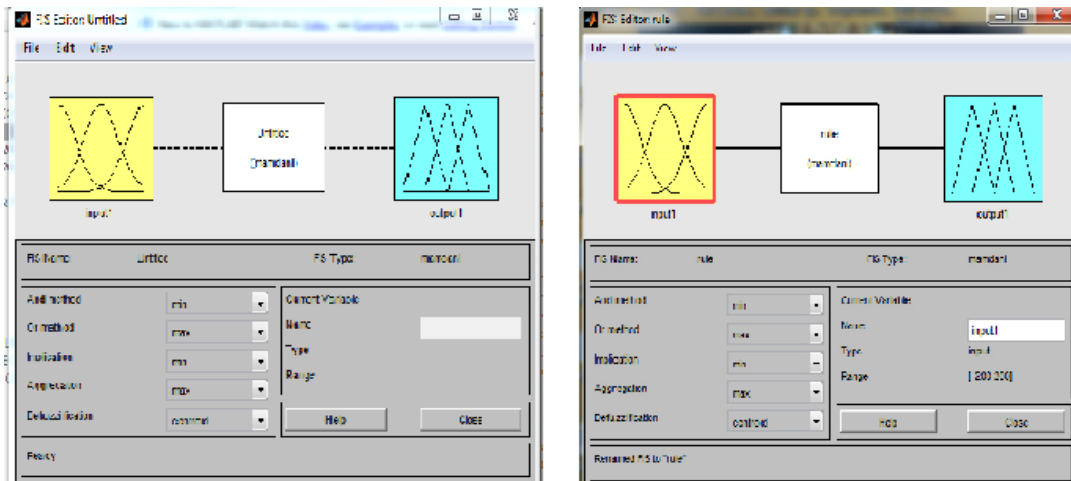

Figure 10: Fuzzy Rules

These results confirmed that the Fuzzy PID controller demonstrates robustness under various operating conditions and shows a very satisfactory performance. It can be easily seen that the overshoot has been considerably reduced with fuzzy logic controller as compared to the PID using classic ZN method. Comparative step response for PID regulated system and FLC controlled system. The fuzzy inference diagram is the composite of all the smaller diagrams presented so far in this section. It simultaneously displays all parts of the fuzzy inference process we have examined [29]-[35]. It's solve problem rise from some plant are defaulted to represent in mathematical model, also in some plant to design the approaches mathematical model you must neglect some parameter.

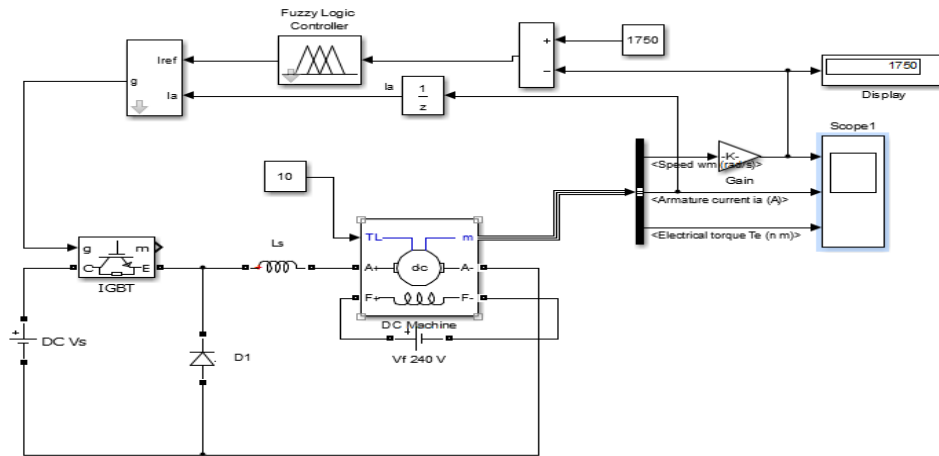

Figure 11: Simulation Model of Separately Excited DC Motor

In order to validate the FLC control strategies as described above, the digital simulation were carried out on a 5 HP, 240V and 1750 rpm separately excited DC drive system whose parameters are mentioned in the MATLAB/Simulink model of system under study with fuzzy controller is shown in Fig.11. The speed of separately excited DC motor has been successfully controlled by using fuzzy logic controller technique.

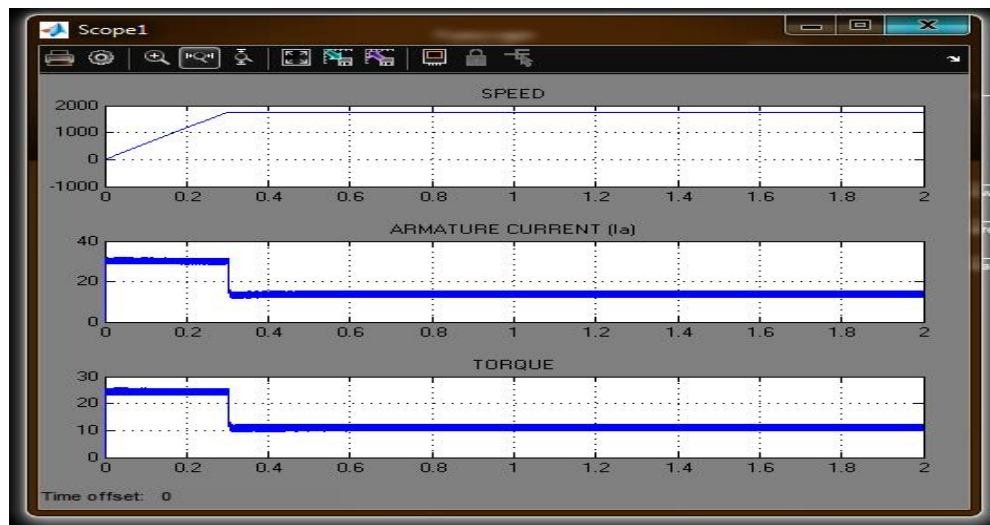

Figure 12: Simulated Waveform of Speeds, Torque and Armature Current

The Fig. 12 shows the speeds, torque and armature current are the simulated waveform of separately excited DC motor. The proportional integral controller is very much useful as it improve steady state response of the system, and it time of response is high but there are some disadvantageous of PI controller is tuning of PI controller, it give high ripple in torque and current , and high peak overshoot and when sudden load is applied over it, the speed is drop very much, these disadvantageous are very much improve by using rule base fuzzy logic controller, as tuning is not required in fuzzy logic controller it reduces the ripple in torque and current very much and there is no peak over shoot in the system, by comparing both the controller fuzzy logic controller is proved to be much superior then PI controller.

5. Conclusion

In this paper the speed of a separately excited DC motor is controlled by using fuzzy logic and PID controller. The simulation results are obtained using MATLAB/Simulink environment. The fuzzy logic response is compared with that of conventional PID controller. The results show that the overshoot, settling time, peak time and control performance has been improved greatly by using fuzzy logic controller. The proposed fuzzy logic controller has more advantages, such as higher flexibility, control, better dynamic and static performance compared with conventional controller. Hence, fuzzy logic controller design was proposed and implemented.

References

- [1] Yi-Ping Hsieh, Jiann-Fuh Chen, Tsorng-Juu Liang and Lung-Sheng Yang, Novel High step up DC-DC Converter with Coupled-Inductor and Switched-Capacitor Techniques for a Sustainable Energy System, *IEEE Trans. Power Electron.* Vol. 26, No. 12, December 2011.
- [2] R.Nagarajan and M,Saravanan, "Performance Analysis of Multicarrier PWM Strategies for Cascaded Multilevel Inverter," *European Journal of Scientific Research (EJSR)*, Vol.92 No.4, pp. 608-625, Dec. 2012.
- [3] R.Nagarajan and M,Saravanan, "A Carrier - Based Pulse Width Modulation Control Strategies for Cascaded Multilevel Inverter," *International Review on Modeling and Simulations (IRMOS)*, Vol 6.No1, pp-8-19, Feb. 2013.
- [4] M.Elangovan, R.Yuvara, S.Sathishkumar and R.Nagarajan, "Modelling and Simulation of High Gain Hybrid Boost Converter," *International Journal of Emerging Technologies in Engineering Research (IJETER)*, Volume 5, Issue 6, pp. 9- 14, June-2017
- [5] O. Lopez, R. Teodorescu, F. Freijedo, and J. DovalGandoy, "Leakage current evaluation of a single-phase transformerless PV inverter connected to the grid," in *Proc. IEEE Appl. Power Electron. Conf.*, 2007, pp. 907–912.
- [6] Dr.R.Nagarajan, S.Sathishkumar, K.Balasubramani, C.Boobalan, S.Naveen and N.Sridhar. "Chopper Fed Speed Control of DC Motor Using PI Controller," *IOSR- Journal of Electrical and Electronics Engineering (IOSR-JEEE)*, Volume 11, Issue 3, Ver. I, pp. 65-69, May – Jun. 2016.
- [7] M. Sridhar, S.Sathishkumar, R.Nagarajan and R.Yuvaraj, "An Integrated High Gain Boost Resonant Converter for PV System," *International Journal of Emerging Technologies in Engineering Research (IJETER)*, Volume 5, Issue 6, pp. 54- 59, June-2017.
- [8] R.Prabhu, R.Nagarajan, N.Karthick and S.Suresh, "Implementation of Direct Sequence Spread Spectrum Communication System Using FPGA," *International Journal of Advanced Engineering, Management and Science (IJAEMS)*, Vol-3.Issue-5, pp. 488-496, May. 2017
- [9] R.Nagarajan, R.Yuvaraj, V.Hemalatha, S.Logapriya, A.Mekala and S.Priyanga, "Implementation of PV - Based Boost Converter Using PI Controller with PSO Algorithm," *International Journal of Engineering And Computer Science (IJECS)*, Volume 6, Issue 3, pp. 20479-20484, March, 2017.
- [10] M.Meenakshi, R.Nagarajan, R. Banupriya and M.Dharani Devi, "Stepped Multicarrier SPWM Techniques for Seven - Level Cascaded Inverter," *International Journal of Emerging Technologies in Engineering Research (IJETER)*, Volume 5, Issue 12, pp. 43- 49, December-2017.
- [11] R.Nagarajan, S.Sathishkumar, S.Deepika, G.Keerthana, J.K.Kiruthika and R.Nandhini, "Implementation of Chopper Fed Speed Control of Separately Excited DC Motor Using PI Controller", *International Journal of Engineering And Computer Science (IJECS)*, Volume 6, Issue 3, pp. 20629-20633, March, 2017.
- [12] B. Liu, S. Duan, and T. Cai, "Photovoltaic dc-building-module-based BIPV system: Concept and design considerations," *IEEE Trans. Power Electron.*, vol. 26, no. 5, pp. 1418–1429, May 2011.

- [13] G. Vidhya Krishnan, R.Nagarajan, T. Durka, M.Kalaiselvi, M.Pushpa and S. Shanmuga priya, "Vehicle Communication System Using Li-Fi Technology," *International Journal of Engineering And Computer Science (IJECS)*, Volume 6, Issue 3, pp. 20651-20657, March 2017.
- [14] R.Nagarajan, J.Chandramohan, S.Sathishkumar, S.Anantharaj, G.Jayakumar, M.Visnukumar and R.Viswanathan, "Implementation of PI Controller for Boost Converter in PV System," *International Journal of Advanced Research in Management, Architecture, Technology and Engineering (IJARMATE)*. Vol.11, Issue.XII, pp. 6-10, December. 2016.
- [15] M.Dharani Devi and R.Nagarajan, "Implementation of Different PWM Control Strategies for Cascaded MLI," *Journal of Network Communications and Emerging Technologies (JNCET)*, Volume 7, Issue 7, pp. 49- 55, July-2017.
- [16] R.Nagarajan and M, Saravanan, "Comparison of PWM Control Techniques for Cascaded Multilevel Inverter" *International Review of Automatic control (IRACO)*, Vol.5, No.6, pp. 815-828. Nov. 2012.
- [17] M.Dharani Devi, M.Malarvizhi and R.Nagarajan, "Development of Multicarrier SPWM Techniques for Cascaded MLI." *International Journal of Computational Engineering Research (IJCER)*, Vol. 7, Issue 10, October 2017, pp. 44-52.
- [18] R Rameshkumar and R Nagarajan, "Sine Multicarrier SPWM Technique for Seven Level Cascaded Inverter," *CiiT-Programmable Device Circuits and Systems*. Vol. 5, Issue- 6, 2013.
- [19] R.Nagarajan and M,Saravanan "Staircase Multicarrier SPWM Technique for Nine Level Cascaded Inverter," 2013 International Conference on Power, Energy and Control (ICPEC), IEEE Press, pp-668-675. 2013.
- [20] G.Carrara, S.Gardella, M.Marchesoni, R.Salutari, G.Sciutto, "A New Multilevel PWM Method: A Theoretical Analysis," *IEEE Trans. Power Electronics*, vol. 7, n.3, July 1992, pp 497-505.
- [21] R.Nagarajan and M, Saravanan. "Performance Analysis of a Novel Reduced Switch Cascaded Multilevel Inverter," *Journal of Power Electronics*, Vol.14, No.1, pp. 48-60, Jan.2014.
- [22] S.Suresh, R.Nagarajan, R.Prabhu and N.Karthick, "Energy Efficient E0 Algorithm for Wireless Transceivers," *International Journal of Engineering and Computer Science (IJECS)*, Volume 6, Issue 7, July 2017, pp. 21982-21985, DOI: 10.18535/ijecs/v6i7.15.
- [23] R. Banupriya, R.Nagarajan, M.Malarvizhi and M.Dharani Devi, "Multicarrier - Based PWM Control Strategies for Five - Level CMLI." *Journal of Network Communications and Emerging Technologies (JNCET)*, Vol. 7, Issue 11, November - 2017, pp. 33-39.
- [24] R.Nagarajan, J.Chandramohan, R.Yuvaraj, S.Sathishkumar and S.Chandran, "Performance Analysis of Synchronous SEPIC Converter for a Stand-Alone PV System," *International Journal of Emerging Technologies in Engineering Research (IJETER)*, Vol. 5, Issue - 5, pp. 12-16, May-2017
- [25] M. Padmavathi and R. Nagarajan, "Smart Intelligent ATM Using LABVIEW," *International Journal of Emerging Technologies in Engineering Research (IJETER)*, Volume 5, Issue 5, pp. 41-45, May-2017.
- [26] L. Zhang, K. Sun, Y. Xing, L. Feng, and H. Ge, "A modular grid-connected photovoltaic generation system based on dc bus," *IEEE Trans. Power Electron.*, vol. 26, no. 2, pp. 523–531, Feb. 2011.
- [27] J. Chandramohan, R. Nagarajan, K. Satheshkumar, N. Ajithkumar, P.A. Gopinath and S. Ranjithkumar, "Intelligent Smart Home Automation and Security System Using Arduino and Wi-fi," *International Journal of Engineering And Computer Science (IJECS)*, Volume 6, Issue 3, pp. 20694-20698, March, 2017.
- [28] K. Anandhi and Dr. R. Nagarajan, "Mutex-Heart: Fail Safe Dual Chamber Cardiac Pacemaker Device with Rate Responsive Control and Cryptographic Security," *IJSRD- International Journal for Scientific Research & Development*. Vol. 3, Issue- 2, pp. 489-493, 2015.
- [29] Q. Li and P. Wolfs, "A review of the single phase photovoltaic module integrated converter topologies with three different dc link configurations," *IEEE Trans. Power Electron.*, vol. 23, no. 3, pp. 1320–1333, May 2008.

- [30] M. Malarvizhi, R. Nagarajan, M. Meenakshi and R. Banupriya, "Unipolar Sine Multicarrier SPWM Control Strategies for Seven - Level Cascaded Inverter," International Journal of Emerging Technologies in Engineering Research (IJETER), Volume 6, Issue 1, pp. 111- 117, January-2018.
- [31] J. Chandramohan, R. Nagarajan, M. Ashok kumar, T. Dineshkumar, G. Kannan and R. Prakash, "Attendance Monitoring System of Students Based on Biometric and GPS Tracking System," International Journal of Advanced Engineering, Management and Science (IJAEMS), Vol-3.Issue-3, pp. 241-246, Mar. 2017.
- [32] N. Karthick, R. Nagarajan, S. Suresh and R. Prabhu, "Implementation of Railway Track Crack Detection and Protection," International Journal Of Engineering And Computer Science (IJECS), Volume 6, Issue 5, May 2017, pp. 21476-21481, DOI: 10.18535/ijecs/v6i5.47
- [33] Ms. C. Hemalatha, Mr. R. Nagarajan, P. Suresh, G. Ganesh Shankar and A. Vijay, "Brushless DC Motor Controlled by using Internet of Things," IJSTE - International Journal of Science Technology & Engineering, Volume -3.Issue-09, pp. 373-377, March- 2017.
- [34] S. Sathishkumar, R. Nagarajan, R. Yuvaraj, M. Sridhar and M. Elangovan, "Implementation of Pwm Technique For Integrated High Gain" IOSR Journal of Engineering (IOSRJEN), Vol. 08, Issue 3, PP. 59-66, March - 2018.
- [35] S. Suresh, R. Nagarajan, L. Sakthivel, V. Logesh, C. Mohandass and G. Tamilselvan, "Transmission Line Fault Monitoring and Identification System by Using Internet of Things," International Journal of Advanced Engineering Research and Science (IJAERS), Vol - 4.Issue - 4, pp. 9-14, Apr- 2017.

*Corresponding author.

E-mail address: krnaga71@ yahoo.com