



A PROFICIENT DETECTION AND RESCUE ASSISTING SYSTEM TO COMBAT FIRE ACCIDENTS OCCURRING IN UNDERGROUND COAL MINES

Mohd Shirazuddin ^{*1}, Syed Musthak Ahmed ^{*2}

^{*1} Research Scholar, JJT University, Jhunjunu, Rajasthan, India

^{*2} Professor and Dean (Academics), SR Engineering College, Warangal, Telangana, India

Abstract:

Working in the field of Coal Mining (CM) is well known and considered among the most dangerous occupations when matched to many other industrial sectors[1], the safety issues associated with the CM workings gets worse when mining is carried out in the underground environment. In addition to the dangers coupled with the fall of roof, side walls and other harsh conditions in the Underground Coal Mine (UCM), the UCM suffers with additional threats such as the gas leakages, heating of coal and the other causes of fire accidents. All these factors raise concerns on improving the safety in the UCMs. The paper presented here focuses and recommends a safety system to tackle the accidents due to fire and to form a rescue assisting system.

Keywords: Coal Mining; Safety; Fire Accidents; Gas Leakages; Underground Environment; Rescue Assisting System.

Cite This Article: Mohd Shirazuddin, and Syed Musthak Ahmed. (2018). "A PROFICIENT DETECTION AND RESCUE ASSISTING SYSTEM TO COMBAT FIRE ACCIDENTS OCCURRING IN UNDERGROUND COAL MINES." *International Journal of Engineering Technologies and Management Research*, 5(5), 128-133. DOI: 10.5281/zenodo.1296879.

1. Introduction

Out of the many large number of industries such as the Construction, Automobiles, Transport Systems, Financial Services and Banking, Chemical Industries, Telecommunication, Pharmaceutical Industries, Public Administration, Entertainment and Recreation, Information Technology, Entertainment and Recreation etc., which has contributes and plays their role efficiently in participating nation's development by creating employment, improving the way of living, increasing country's GDP and safety etc., there is yet one industry which not just creates employment or increases country's GDP but also contributes in fulfilling the nation's demand of energy as one of the most abundant source of energy; the industry is the CM industry which has not just accounted in meeting India's energy needs of about 55% ^[2] but also meeting 41% of global electricity through power driven by coal – fired power plants ^[3]. The CM due to the safety related issues which makes it known as the harsh environment to work requiring an improvement in the safety methods and implementations. No doubt, the recent technological advancements and the state – of – the – art technologies have considerably reduced the CM accidents but still somewhere there is left a room for improvements in the safety requirements ^[4].

Moreover, the beneficial nature of the CM in not just providing employment to a large number of people but also in contributing to the nation's GDP and also fulfilling the need as one of the most abundantly available energy source attracts and encourages to develop an improved system of safety to not just save this precious energy source but also to partake in a noble cause of providing safety to the people and saving people's lives which is more valuable and precious than any other task^[5].

Talking about combating fire accidents which are among the major causes of accidents which cause huge loss not only to the mine infrastructure but also to the lives of the miners working in the CM. In order to develop an efficient fire – fighting and rescue assisting system, it is required to set up efficient plans to tackle the unexpected events which can result in fire accidents. To reduce the probability of the fire accidents and the losses thereafter, one of the efficient ways is to develop a system which has effective fire preparedness and a system which is fast responsive in not just detecting the fire accidents but also in alerting the monitoring station or any associated authorized department of safety and taking measures such as extinguishing fire by suitable extinguishers and confining fire in a small area through the use of fire blocking gate which is the basic idea of the research work summarized in this paper.

2. Methodology

The research work proposes an implementation of the wireless communication system through the concept of Internet of Things (IoT) to accomplish the task of communicating the sensor information about the possible detection of fire to the monitoring station or safety department located anywhere around the world as long as there is an availability of internet service and connection between the safety unit and the overall system.

The research work is primarily based on developing a method to reduce the fire accidents by detecting the fire which can be caused due to many reasons such as the methane explosions and the spontaneous combustion of coal which is a reason for appearance of about 75% of the coal fires in India^[6] etc., and alerting the miners by triggering buzzer, transmitting sensor gathered information to the monitoring station through wireless network made using IoT, operating the fire extinguisher and also making use of the fire blocking gate concept to confine and limit the fire in a small area, thus forming a system which not just assists in detecting and extinguishing fire but also assist in carrying out rescue operations by sending the alert signals to the monitoring stations. The status of the fire sensor can be accessed on a large number of devices such as the PCs, tabs, mobile phones, laptops etc., through IoT^[7]. The technical aspects and workings of the research work is briefly described in the below sections.

3. Block Diagram and Working

The design of the proposed system is shown in the below figure (1) which contains:

- Fire sensor control circuit
- Main Controlling Unit (MCU)
- Wireless Communication Unit (WCU)
- Fire blocking gate circuit and
- Buzzer circuit

The block diagram shows the basic connections between the above circuit modules connected to perform the above mentioned safety operations. The fire logic circuit has the provision to adjust the level of fire to be the threshold level exceeding which the MCU treats it as a fire threat as per the instructions stored in the controller.

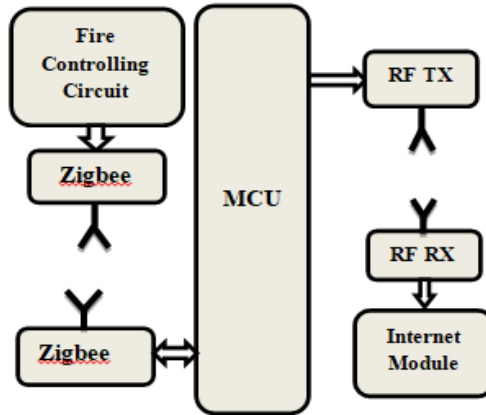

Figure 1: Complete system design

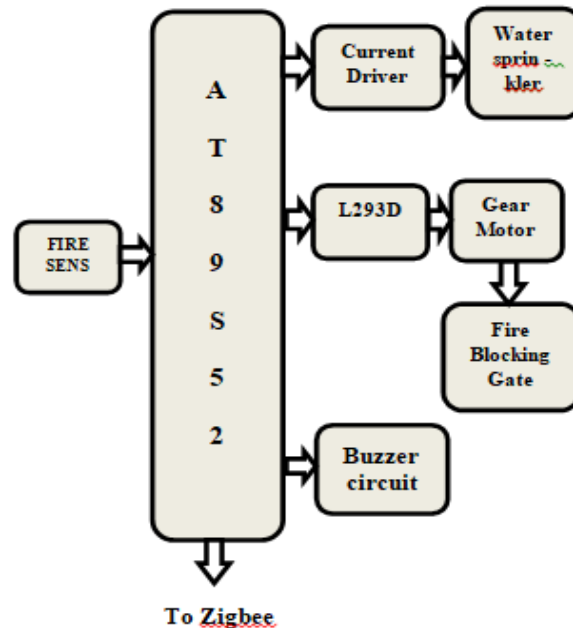

Figure 2: Fire controlling circuit

Three controllers are involved in this research viz., the AT89S52, LPC1768 and the PIC16F877A controllers. The below sequence of operations are performed by the three controllers:

- The AT89S52 controller detects the change in the fire and when the fire threshold is reached, it sends the control signals to trigger the buzzer, activate the fire extinguisher and the fire blocking gate and sends the alerting signal to the MCU built around LPC1768 as shown in figure (2).

- The MCU controlled by the LPC1768 allows the provision to connect to a large number of sensor units through Zigbee communication and read data from the sensors situated all across the mine area. The MCU, then processes the received data and sends the data on the Internet to be monitored with the help of the internet unit built with PIC16F877A controller.
- The PIC16F877A controller hosts the data on the internet with the help of the Ethernet module.
- The Zigbee communication is used for communicating the sensor information from the UCM to the MCU as GSM technique fails to get network coverage in the UCM and the wired communication techniques suffers with shortcomings based on wire complexities, difficulties in making system upgradations or changes, makes troubleshooting difficult, increases cost^[8] and can produce a spark which can result in fire in worst case scenarios etc. The Zigbee provides an efficient and reliable communication in the underground environments as well thereby allowing the data from the UCM to be transmitted to the MCU efficiently. To further cut down the use of wires, RF communication is also used to transfer the information from the MCU to the internet module.

4. Results

The experimental results obtained in carrying out the proposed research work are shown in the below figures (3), (4) and (5). Figure (3) showing the fire sensor and the inputs to the actuators readings in the normal and the situation indicates the fire accident.

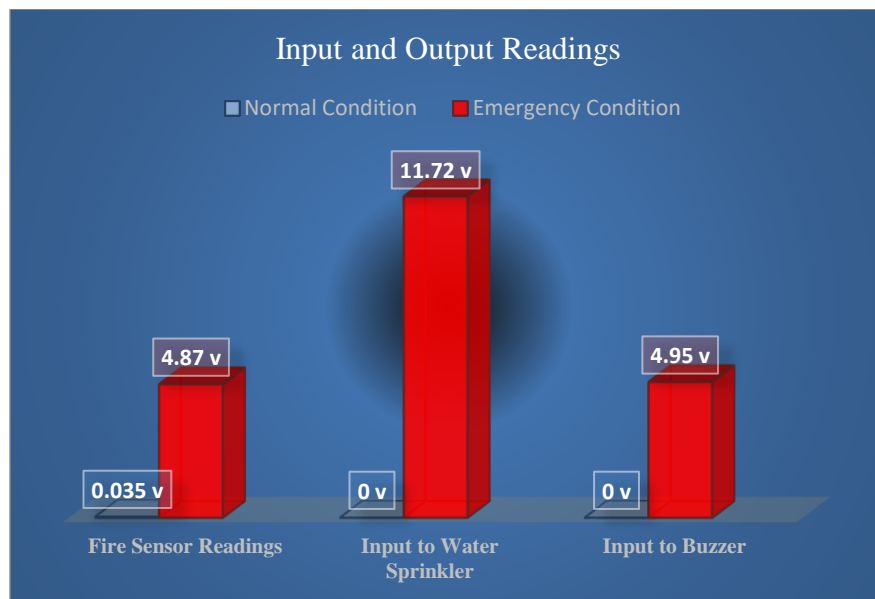

Figure 3: Sensor and Actuator voltages

The outputs of the proposed research work can be monitored on mobile, laptops, tablets, notebooks, PC etc., provided with an internet connection. The outputs screenshots are shown in the below figures (4) and (5).

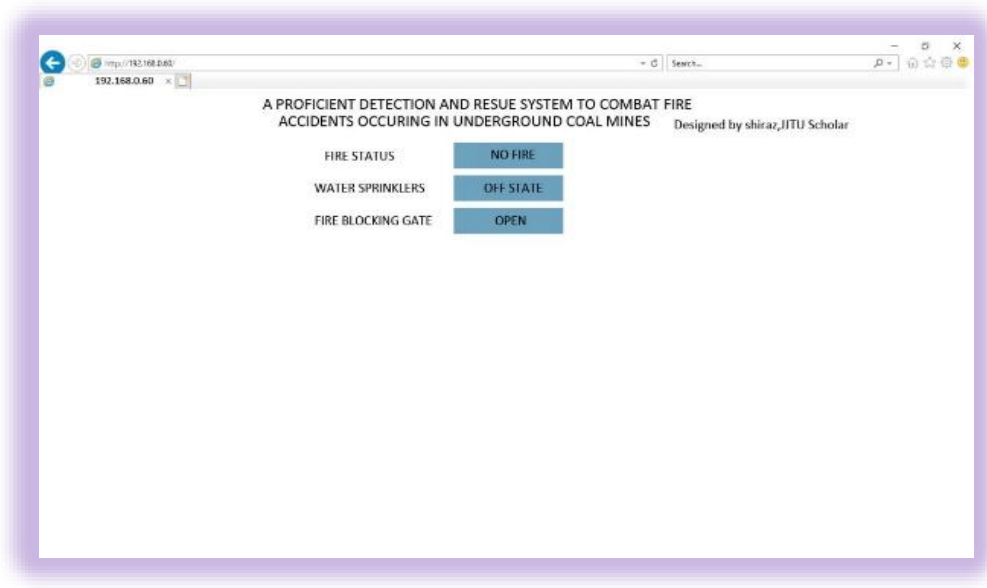

Figure 4: Normal Mine Condition

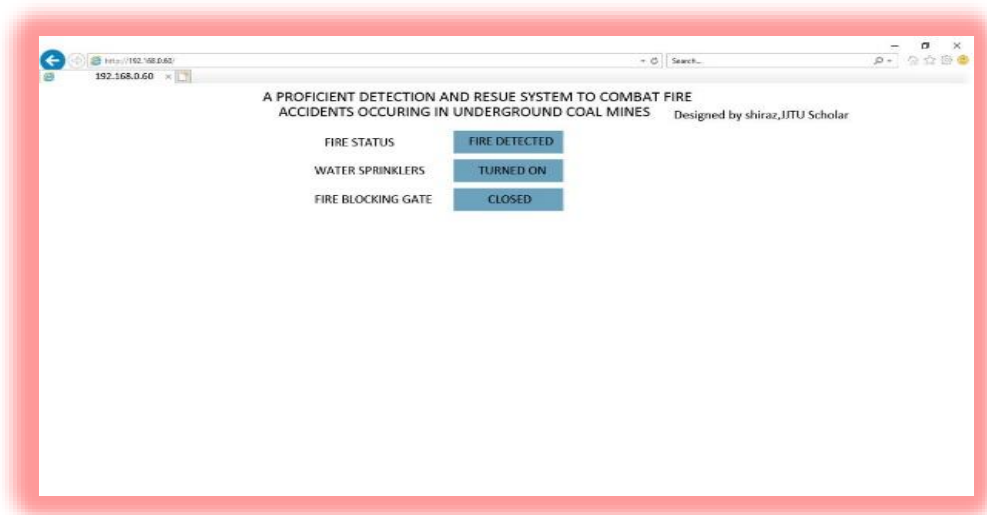

Figure 5: During Disaster Condition

5. Conclusion

The proposed research work is mainly based on improving the safety in the UCM and to provide a better and safe working environment to the miners ensuring that miners work to their full potential without having to be worried about the possible threats in the harsh mining environment. The research work proposes a system built around LPC1768 and the other popular and efficient components and performs the wireless operations with the help of the Zigbee, IoT and RF communication techniques. The proposed system is will achieve a greater level of safety in the UCM if the system is implemented in accordance with the UCM under consideration and considering the other related factors as well such as safety awareness among the miners, the outside atmospheric conditions, previous history of mine accidents etc.

References

- [1] Wen, S., Fei, W., Jianbo, D. (2010). A emergency communication system based on WMN in underground mine. International Conference on Computer Application and System modelling, vol. 4, pp. 624 – 627.
- [2] Qaisar, S., Ahmad, M. (2014). Production, Consumption and Future Challenges of Coal in India. International Journal of Current Engineering and Technology, Vol. 4, pp. 3437 – 3440.
- [3] ‘Coal mining’, (2015), World Coal Association, Available: <https://www.worldcoal.org/coal/coal-mining>. [Last accessed: 16 – Mar – 2018].
- [4] Tao, P., Xiaoyang, L. (2011). Hybrid wireless communication system using Zigbee and WI – Fi technology in the coal mine tunnels. Third IEEE International Conference on Measuring Technology and Mechatronics Automation, pp. 340 – 343.
- [5] Vinothkumar, C., Kumar, K., Elavarasan, R. (2014). An integrated surveillance system to detect fire and gas leakage in petrochemical industry using Zigbee protocol. International Journal on Advanced Research in Electrical, Electronics and Instrumentation Engineering, vol. 3, pp. 11146 – 11154.
- [6] Singh, R., (2013). Spontaneous heating and fire in coal mines. The 9th Asia Oceania Symposium on Fire Science and Technology, pp. 78 – 90.
- [7] Mohammed, Z., Ahmed, E. (2017), Internet of Things Applications, Challenges and Related Future Technologies. World Scientific News, pp. 126 –148.
- [8] Baishun, S., Zhengduo, P., Guoying, M. (2010). Design of the mine gas sensor based on Zigbee. Proceedings of the Third International Symposium on Computer Science and Computational Technology, pp. 77 -81.