



FULLY AUTOMATED HYBRID HOME CLEANING ROBOT

Amit Sharma ^{*1}, Akash Choudhary ², Akshay Gaur ³, Amit Rajpurohit ⁴

^{*1, 2, 3, 4} Department of Electrical Engineering, Swami Keshvanand Institute of Technology
Management and Gramothan, India

Abstract:

Technology is getting better and better day by day, Robots is being introduced as an alternative of humans. In this era it is necessary that all parts of the society grow equally either it is space research, medical or automobile same thing applies on the domestic sector nowadays cleaning method is being shifted towards robotic cleaners. This paper presents the design and development of Fully Automated Hybrid Home Cleaning Robot. It can perform tasks like moping and vacuum cleaning without any help of humans.

Keywords: Autonomous; Arduino; IR Sensor; Ultrasonic Sensor; Driver IC; Hybrid Cleaning Robot.

Cite This Article: Amit Sharma, Akash Choudhary, Akshay Gaur, and Amit Rajpurohit. (2018). "FULLY AUTOMATED HYBRID HOME CLEANING ROBOT." *International Journal of Engineering Technologies and Management Research*, 5(3), 219-225. DOI: 10.5281/zenodo.1218184.

1. Introduction

In 21 century the world is rapidly being acquired by robots, in recent years we have seen many types of floor cleaners most of them are based on the simple application of vacuum. In our research we developed a floor cleaner which is hybrid floor cleaner (vacuum and mopping), it performs all tasks automatically so we called it fully automatic hybrid home cleaning robot. Mainly we use Arduino 328p as controller which works with sensing devices IR sensor and ultrasonic sensor. It uses 3 motors, 2 for wheels and one for mopping. Vacuum unit is at the front of robot to suck all the dust particles. Motor driver IC LM293D is used for driving all three motors and 12 V battery is used as power source. IR and ultrasonic sensors is used for sensing obstacles in way of robot. Robot is operated by an advanced developed algorithm which incorporates the action of sensors and motors.

We also used reusable things for development of this robot, it decreases its overall cost and ensure that it is eco-friendly.

2. Literature Review

Electrolux Trilobite by the Swedish household and professional appliances manufacturer Electrolux.in was the first floor cleaner robot introduced in 1997, one of the trilobite vacuum was

featured on the BBC's science program, TOMORROW'S WORLD. In 2001, the British technology company Dyson built and demonstrated a robot vacuum known as the DC06. However, it was never released to the market because it was very costly.

Roomba is a series of autonomous robotic vacuum cleaners sold by iRobot. Introduced in September 2002 [1]. Roomba features a set of sensors that enable it to perform its tasks. For instance, the Roomba is able to change direction upon encountering obstacles, to detect dirty spots on the floor, and to sense steep drops to keep it from falling down stairs. Roomba uses two independently operating side wheels that allow 360° turns in place. A rotating, 3-prong spinner brush can sweep debris from square corners into the vacuum slot under the round unit.

The Roomba units have a range of models with the 400 to 900 series, which provide several different features, such as faster speed, separate sweep canister, 5x stronger vacuum, obstacle avoidance, or performance maps displayed via a phone app. However, some parts of the Roomba models are interchangeable between related models, allowing a mix/match of features, or switching into other units for longer battery operation. The 900 series Roombas also feature a camera, which works in conjunction with onboard mapping and navigation software to systematically cover floor area. Additionally, some Roomba units can adapt to perform other, more creative tasks, using an embedded computer in conjunction with the Roomba Open Interface.

Dyson's EYE-360 is famous and very smart vacuum cleaner, it uses 360 degree panoramic vision camera [2].

3. Design and Working

Mainly it consist 4 parts Chassis, mopping mechanism, vacuum cleaning, wheels driving. All these parts are described below.

3.1. Chassis

The main body of robot is called chassis, it hold all the parts of the robot. We use light weight wooden frame as a chassis because it is cheap, easily available and great strength. We modified its shape according to requirement. It can hold weight up to 10 kg, much higher than requirement.

3.2. Mopping

Mop is the main part of the machine it cleans the floor. We used circular mop, which is moved by DC motor in circular motion. It is assembled beneath the wooden frame between wheels.

3.3. Vacuum

Vacuum is used for dust sucking purpose it is assembled at the front part of the robot. It sucks all the dust and collect this in a box. Vacuum is powered by the 12V battery.

3.4. Wheeling System

Wheels are the main part of any movable machine here we use 2 small size wheels with rubber grip. Both the wheels run by two 100 rpm DC motors. These wheels is controlled by microcontroller

4. Components of Robot

4.1. Microcontroller (Arduino Uno)

Arduino plays a major role in automation .It acts as brain of the robot .It operates around the voltage of 3.3 volt. It uses atmega16 on its core which uses ARM processor .It has 28 digital I/O pins and 6 analog output pins. From 28 digital pins 6 are PWM (Pulse Width Modulation) pins. 2 DAC pins use 16 bit resolution and operates by the help of analog Write () function. It has 1 USB ports. Such as:-Programming USB port, Native USB Port We can feed the program through programming USB port . Every program has 2 functions in its body.



Figure 1: Arduino (AtMega 328P)

4.2. Motor Driver

We are using here L293D motor driver which has 16 pins 8 on each side. We can control maximum 2 motors connecting on each side. Motor Driver On the left side two terminals OutputA1 and OutputA2 are connected to two terminals of motor and similarly on the right hand side OutputB1 and OutputB2 are connected to motor terminals. The inputs from the arduino board are connected through InputA1, InputA2, InputA3, and InputA4.Accordingly motor moves forward, backward, left side and right side.

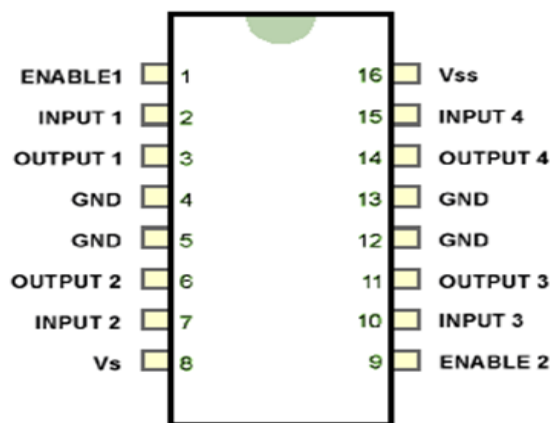

Figure 2: Motor Driver L293D

4.3. Ultrasonic Sensor

Here we are using 2 Ultrasonic sensors. It is a type of electronics component that uses ultrasonic transmitter and receiver pair to send and collect signals resulting in proper sense of obstacles. The more the resonant frequency the lesser will be the wavelength of transmitted radiation and it will provide good surrounding condition. The more directional the sonic wave the more resolution in the measurement come. Sensitivity helps in decreasing signal to noise ratio. Here we used two transducers of 40khz.as shown below.



Figure 3: Ultrasonic Sensor

4.4. IR Sensor

The basic concept of an Infrared Sensor which is used as Obstacle detector is to transmit an infrared signal, this infrared signal bounces from the surface of an object and the signal is received at the infrared receiver. There are five basic elements used in a typical infrared detection system: an infrared source, a transmission medium, optical component, infrared detectors or receivers and signal processing. Infrared lasers and Infrared LED's of specific wavelength can be used as infrared sources.



Figure 4: IR Sensor

4.5. DC Motor

DC motor is an electrical machine that utilizes electric power resulting in mechanical power output. Normally the motor output is a rotational motion of the shaft. The input may be direct current supply or alternating supply. But in case of DC motor direct current is used. The mechanism of dc motor is like a bar wound with wire is placed in between 2 magnets having North and South Pole. When it is provided with electric supply the wire becomes energized resulting in rotational motion which leads to rotational output. Here we are using two 100 rpm dc motors for wheel driving and one 300 rpm dc motor for rotating the mop.



Figure 5: DC Motor

5. Results and Discussions

The objective of this project is to make a fully automated hybrid home cleaning robot. Which is fully autonomous and can perform tasks like mopping and vacuum cleaning of floor. After the testing we find that it can perform all tasks very well without any hurdle. We tested our robot on different parameters like path following, obstacle avoidance, navigation, mopping and vacuum mechanism. Details of all these parameters is given below.

5.1. Obstacle Avoidance

In home there are many things, these things can halt the operation of mopping we need to counter this problem for this we used ultrasonic sensors and IR sensors. Sensors are sensing obstacles and giving command to the microcontroller. Microcontroller is processing the data and driving both motors according to it.

5.2. Navigation

Navigation is the way to find the path in real world, for a robotic vehicle it is necessary that it should be well guided and don't forgets its way. For insuring it we drive our bot in a room and collect the data. In early process we face some problem by changing the codes and sensor position we tackle this problem now robotic cleaner is working well.

5.3. Mopping Mechanism

Mopping is the essential part of floor cleaning process. A good map should cover all the area. We use a cotton mop, this mop is moving in clock and anti-clockwise direction for 2 cycles. Till now it is working satisfactory.

5.4. Vacuum Mechanism

Vacuum is used to suck the dust from floor. We used a 5000 rpm motor for this, best part in our vacuum is the use of unused materials like water bottle. It can suck all the dust from floor. We use this on different size debris like paper and dust and it is working well.



Figure 6: Fully Automated Hybrid Home Cleaning Robot

6. Conclusions and Recommendations

The robot thus developed is fully operational and gives desired results. It is being tested in a testing room which results in successful outcome. The mopping design should be modified in future because the current design has few problems. Few of those are the motor is not detachable and the high rpm leads to vibration of the whole system. Motor used in vacuum is consuming the power rapidly, it needs to do some changes.

Acknowledgements

I express my sincere gratitude to Ms. Nikita Mittal, Assistant Professor, Department of Electrical Engineering, SKIT, Jaipur who spared her valuable time from her busy schedule and extended

her valuable guidance, expertise and vision to guide me through the preparation of this project and research paper.

References

- [1] Irobot.com, 'iRobot Corporation ', 2018. [Online]. Available: <http://www.irobot.com/>.
- [2] Dyson.com, 'Latest Dyson Vacuum Cleaner Technology | Dyson.com', 2018. [Online]. Available: <http://www.dyson.com/>.
- [3] Dyson 360 Eye robot, 'Dyson 360 Eye robot', 2018. [Online]. Available: <https://www.dyson.com/>.
- [4] Uman Khalid, Muhammad Faizan Baloch,, Haseeb Haider, Muhammad Usman Sardar, Muhammad Faisal Khan Abdul Basit Zia and Tahseen Amin Khan Qasuria Faculty of Electronic Engineering, Ghulam Ishaq Khan “Smart Floor Cleaning Robot (CLEAR)” Institute of Engineering Sciences and Technology, Pakistan Hamdard Institute of Engineering & Technology, Hamdard University, Karachi, Pakistan.
- [5] Harvey Koselka, Bret A. Wallach, David Gollaher, “Autonomous floor mopping apparatus,” U.S. Patent 6741054 B2, May 25, 2004.
- [6] Manya Jain, Pankaj Singh Rawat, Assist. Prof. Jyoti Morbale B.Tech in Electronics Engg. , Assist. Professor in Electronics Engg. ”Automatic Floor Cleaner” BVDUCOE, Pune, Maharashtra, India.

*Corresponding author.

E-mail address: amitsharma.sheru@ gmail.com